

**UNITED STATES
SECURITIES AND EXCHANGE COMMISSION
WASHINGTON, D.C. 20549**

FORM 8-K

CURRENT REPORT

Pursuant to Section 13 or 15(d) of the Securities Exchange Act of 1934

Date of Report (Date of earliest event reported): May 07, 2026

DIODES INCORPORATED

(Exact name of Registrant as Specified in Its Charter)

Delaware
(State or Other Jurisdiction
of Incorporation)

002-25577
(Commission File Number)

95-2039518
(IRS Employer
Identification No.)

4949 Hedgcoxe Road, Suite 200
Plano, Texas
(Address of Principal Executive Offices)

75024
(Zip Code)

Registrant's Telephone Number, Including Area Code: 972 987-3900

(Former Name or Former Address, if Changed Since Last Report)

Check the appropriate box below if the Form 8-K filing is intended to simultaneously satisfy the filing obligation of the registrant under any of the following provisions:

- Written communications pursuant to Rule 425 under the Securities Act (17 CFR 230.425)
- Soliciting material pursuant to Rule 14a-12 under the Exchange Act (17 CFR 240.14a-12)
- Pre-commencement communications pursuant to Rule 14d-2(b) under the Exchange Act (17 CFR 240.14d-2(b))
- Pre-commencement communications pursuant to Rule 13e-4(c) under the Exchange Act (17 CFR 240.13e-4(c))

Securities registered pursuant to Section 12(b) of the Act:

Title of each class	Trading Symbol(s)	Name of each exchange on which registered
Common Stock, Par Value \$0.66 2/3	DIOD	The Nasdaq Stock Market LLC

Indicate by check mark whether the registrant is an emerging growth company as defined in Rule 405 of the Securities Act of 1933 (§ 230.405 of this chapter) or Rule 12b-2 of the Securities Exchange Act of 1934 (§ 240.12b-2 of this chapter).

Emerging growth company

If an emerging growth company, indicate by check mark if the registrant has elected not to use the extended transition period for complying with any new or revised financial accounting standards provided pursuant to Section 13(a) of the Exchange Act.

Item 2.02 Results of Operations and Financial Condition.

On May 7, 2026, Diodes Incorporated (the “Company”) issued a press release announcing its first quarter ended March 31, 2026 financial results. A copy of the press release is furnished as Exhibit 99.1.

In the press release, the Company utilizes financial measures and terms not calculated in accordance with generally accepted accounting principles in the United States (“GAAP”) in order to provide investors with an alternative method for assessing the Company’s operating results in a manner that enables investors to more thoroughly evaluate its current performance as compared to past performance. The Company also believes these non-GAAP measures provide investors with a more informed baseline for modeling the Company’s future financial performance. Management uses these non-GAAP measures for the same purpose. The Company believes that investors should have access to the same set of tools that management uses in analyzing results. These non-GAAP measures should be considered in addition to results prepared in accordance with GAAP, but should not be considered a substitute for or superior to GAAP results and may differ from similar measures used by other companies. See Exhibit 99.1 for a description and reconciliation with GAAP of the non-GAAP measures used.

The information furnished in this Item 2.02, including the exhibit incorporated by reference, will not be treated as “filed” for the purposes of Section 18 of the Securities Exchange Act of 1934, as amended (the “Exchange Act”), or otherwise subject to the liabilities of that section. This information will not be deemed incorporated by reference into any filing under the Securities Act of 1933, as amended (the “Securities Act”), or into another filing under the Exchange Act, unless that filing expressly refers to specific information in this Report.

Item 7.01 Regulation FD Disclosure.

The press release furnished as Exhibit 99.1 also provides an update on the Company’s business outlook, that is intended to be within the safe harbor provided by the Private Securities Litigation Reform Act of 1995 (the “Act”) as comprising forward looking statements within the meaning of the Act.

The information furnished in this Item 7.01, including the exhibit incorporated by reference, will not be treated as “filed” for the purposes of Section 18 of the Exchange Act, or otherwise subject to the liabilities of that section. This information will not be deemed incorporated by reference into any filing under the Securities Act, or into another filing under the Exchange Act, unless that filing expressly refers to specific information in this Report.

Item 8.01 Other Events.

From time to time, Diodes Incorporated (the “Company”) may give corporate presentations to its customers, suppliers and other related interested parties. Copies of the Company’s corporate presentation slides, updated on May 7, 2026, are attached herewith as Exhibit 99.2 and Exhibit 99.3. Exhibit 99.2 provides an update focused on the Company’s first quarter 2026 financial results and Exhibit 99.3 is used in the Company’s investor relations presentations.

Forward-Looking Statements

Statements in this Current Report on Form 8-K (including in the documents attached as Exhibit 99.1, Exhibit 99.2 and Exhibit 99.3 contain forward-looking statements that involve future risks and uncertainties as contemplated by the safe harbor provided by the Private Securities Litigation Reform Act of 1995. All statements, other than statements of historical facts, included in this Current Report on Form 8-K (including the documents attached as Exhibit 99.1, Exhibit 99.2 and Exhibit 99.3 should be regarded as “forward-looking statements” and Exhibit 99.1, Exhibit 99.2 and Exhibit 99.3 contain a more detailed listing of the risks and uncertainties associated with those forward-looking statements. Diodes undertakes no obligation to update publicly any forward-looking statements, whether as a result of new information, future events or otherwise, except as required by applicable law.

Item 9.01 Financial Statements and Exhibits.

(d) Exhibits.

<u>Exhibit Number</u>	<u>Description</u>
99.1	Press release dated May 7, 2026.
99.2	First Quarter 2026 Financial Results.
99.3	Corporate slides for investor relations presentation.
104	Cover Page Interactive Data File (embedded within the Inline XBRL document).

SIGNATURES

Pursuant to the requirements of the Securities Exchange Act of 1934, the registrant has duly caused this report to be signed on its behalf by the undersigned thereunto duly authorized.

DIODES INCORPORATED

Date: May 7, 2026

By: /s/Brett R. Whitmire
Brett R. Whitmire
Chief Financial Officer



Diodes Incorporated Reports First Quarter 2026 Financial Results

1Q Revenue Increased over 20% and EPS Up over 100% YoY

Plano, Texas – May 7, 2026 -- Diodes Incorporated (Diodes) (Nasdaq: DIOD) today reported its financial results for the first quarter ended March 31, 2026.

First Quarter Highlights

- Revenue was \$405.5 million, compared to \$332.1 million in the first quarter 2025 and \$391.6 million in the prior quarter;
- GAAP gross profit was \$128.8 million, compared to \$104.7 million in the first quarter 2025 and \$121.9 million in the prior quarter;
- GAAP gross profit margin was 31.8 percent, compared to 31.5 percent in the first quarter 2025 and 31.1 percent in the prior quarter;
- GAAP net income was \$15.0 million, compared to GAAP net loss of \$4.4 million in the first quarter 2025 and GAAP net income of \$10.2 million in the prior quarter;
- Non-GAAP adjusted net income was \$19.8 million, compared to \$8.8 million in the first quarter 2025 and \$15.7 million in the prior quarter;
- GAAP EPS was \$0.32 per diluted share, compared to GAAP loss per share of \$0.10 per share in the same quarter a year ago and GAAP EPS of \$0.22 per diluted share in the prior quarter;
- Non-GAAP EPS was \$0.43 per diluted share, compared to \$0.19 per diluted share in the first quarter 2025 and \$0.34 per diluted share in the prior quarter;
- Excluding \$6.0 million, net of tax, non-cash share-based compensation expense, both GAAP net income and non-GAAP adjusted net income would have increased by \$0.13 per diluted share;
- EBITDA was \$49.4 million, or 12.2 percent of revenue, compared to \$26.2 million, or 7.9 percent of revenue in the same quarter a year ago and \$41.9 million, or 10.7 percent of revenue in the prior quarter;
- Achieved \$64.3 million cash flow from operations and \$32.4 million of free cash flow, including \$31.9 million of capital expenditures. Net cash flow was a positive \$26.9 million.

Commenting on the results, Gary Yu, President and CEO of Diodes, stated, "Our first quarter revenue grew 22% year-over-year and an above-seasonal 3.5% sequentially, highlighting the solid demand recovery and momentum we are seeing across our key focus areas of automotive, industrial and AI-server related applications. In fact, this quarter is the fifth consecutive quarter of double-digit year-over-year growth and the highest percentage increase since the fourth quarter of 2021. Revenue in Europe led the growth as we continued to benefit from increased opportunities and orders from automotive customers as well as improved demand across broad industrial applications.

"Additionally, gross margin improved 70 basis points sequentially due mainly to the higher revenue contribution from the automotive and industrial markets, which totaled 44% of product revenue, combined with improving utilization. Notably, we delivered an over 100% year-over-year increase in quarterly earnings, clearly demonstrating the operating leverage in our model.

"After formally releasing our 3-year interim financial targets earlier this year, which includes reaching \$2 billion in annual revenue, \$700 million in gross profit and over \$4.00 in non-GAAP EPS, this quarter was a great first step toward executing on these goals. Content expansion, design win momentum and new product introductions will continue to be the cornerstones of our growth initiatives, combined with increased manufacturing and cost efficiencies to further drive margin expansion."

First Quarter 2026

Revenue for first quarter 2026 was \$405.5 million, compared to \$332.1 million in the first quarter 2025 and \$391.6 million in the prior quarter.

GAAP gross profit for the first quarter 2026 was \$128.8 million, or 31.8 percent of revenue, compared to \$104.7 million, or 31.5 percent of revenue, in the first quarter 2025 and \$121.9 million, or 31.1 percent of revenue, in the prior quarter.

GAAP operating expenses for first quarter 2026 were \$109.0 million, or 26.9 percent of revenue, and on a non-GAAP basis were \$103.9 million, or 25.6 percent of revenue, which excludes \$3.9 million acquisition-related intangible asset cost and \$1.1 million of board/officer retirement expense. GAAP operating expenses in the first quarter 2025 were \$103.4 million, or 31.1 percent of revenue and \$108.7 million, or 27.8 percent of revenue, in the fourth quarter 2025.

First quarter 2026 GAAP net income was \$15.0 million, or \$0.32 per diluted share, compared to GAAP net loss in the first quarter 2025 of \$4.4 million, or a loss of \$0.10 per diluted share and GAAP net income in the prior quarter of \$10.2 million, or \$0.22 per diluted share.

First quarter 2026 non-GAAP adjusted net income was \$19.8 million, or \$0.43 per diluted share, which excluded, net of tax, \$3.2 million of acquisition-related intangible asset amortization cost, \$0.9 million of board/officer retirement expense and \$0.7 million of loss on investments. This compares to non-GAAP adjusted net income of \$8.8 million, or \$0.19 per diluted share, in the first quarter 2025 and \$15.7 million, or \$0.34 per diluted share, in the prior quarter.

The following is an unaudited summary reconciliation of GAAP net income to non-GAAP adjusted net income and per share data, net of tax (*in thousands, except per share data*):

	Three Months Ended March 31, 2026	
Per-GAAP net income	\$	14,961
Diluted earnings per share (per-GAAP)	\$	0.32
Adjustments to reconcile net income to non-GAAP net income:		
Amortization of acquisition-related intangible assets		3,235
Board member/Officer retirement		862
Gain/Loss on Investments		733
Non-GAAP adjusted net income	\$	19,791
Non-GAAP diluted earnings per share	\$	0.43

Note: Throughout this release, we refer to "net income/loss attributable to common stockholders" as "net income/loss."

(See the reconciliation tables of GAAP net income to non-GAAP adjusted net income near the end of this release for further details.)

Included in first quarter 2026 GAAP and non-GAAP adjusted net income was approximately \$6.0 million, net of tax, non-cash share-based compensation expense. Excluding share-based compensation expense, GAAP earnings per share ("EPS") and non-GAAP adjusted EPS would have increased by \$0.13 per share for the first quarter 2026, compared to \$0.11 for the first quarter 2025 and \$0.12 per share in the prior quarter.

EBITDA (a non-GAAP measure), which represents earnings before net interest expense, income tax, depreciation and amortization, in the first quarter 2026 was \$49.4 million, or 12.2 percent of revenue, compared to \$26.2 million, or 7.9 percent of revenue, in the first quarter 2025 and \$41.9 million, or 10.7 percent of revenue, in the prior quarter. For a reconciliation of GAAP net income to EBITDA, see the table near the end of this release for further details.

For the first quarter 2026, net cash provided by operating activities was \$64.3 million. Net cash flow was positive \$26.9 million. Free cash flow (a non-GAAP measure) was \$32.4 million, which includes \$31.9 million of capital expenditures.

Balance Sheet

As of March 31, 2026, the Company had approximately \$409 million in cash and cash equivalents, restricted cash, and short-term investments. Total debt (including long-term and short-term) amounted to approximately \$55 million and working capital was approximately \$891 million.

The results announced today are preliminary and unaudited, as they are subject to the Company finalizing its closing procedures and completion of the quarterly review by its independent registered public accounting firm. As such, these results are subject to revision until the Company files its Form 10-Q for the quarter ending March 31, 2026.

Business Outlook

Gary Yu further commented, "For the second quarter of 2026, we expect revenue to be approximately \$435 million, plus or minus 3 percent, representing an 18.8 percent increase year-over-year and a 7.3 percent increase sequentially at the mid-point. This quarter will be the sixth consecutive quarter of double-digit year-over-year growth and another above seasonal sequential growth quarter. GAAP gross margin is expected to be 32.8 percent, plus or minus 1 percent. Non-GAAP adjusted EPS is expected to be \$0.60, plus or minus \$0.10."

A reconciliation of our forward-looking non-GAAP EPS to the most directly comparable GAAP measures is not provided because such items cannot be reasonably calculated without unreasonable efforts due to the unpredictability of the amounts and timing of events affecting the items we exclude, including acquisition-related intangible asset costs, board member/officer retirements, acquisition-related costs, restructuring costs, gain/loss on investment, non-cash mark-to-market investment adjustments, impairment of equity investment, and other charges.

Conference Call

Diodes will host a conference call on Thursday, May 7, 2026 at 4:00 p.m. Central Time (5:00 p.m. Eastern Time) to discuss its first quarter financial results. Investors and analysts may join the conference call by dialing **1-833-634-2590**; international callers may join the teleconference by dialing **+1-412-317-6038**. A telephone replay of the call will be made available approximately two hours after the call and will remain available until May 14, 2026 at midnight Central Time. The replay number is 1-855-669-9658 with an access code of 9209755 followed by the # key. International callers should dial +1-412-317-0088 and enter the same pass code at the prompt followed by the # key.

Additionally, this conference call will be broadcast live over the Internet and can be accessed by all interested parties on the Investor Relations section of the Company's website. To listen

to the live call, please go to the investors' section of Diodes' website and click on the conference call link at least 15 minutes prior to the start of the call to register, download and install any necessary audio software. For those unable to participate during the live broadcast, a replay will be available shortly after the call on Diodes' website for approximately 90 days.

About Diodes Incorporated

Diodes Incorporated (Nasdaq: DIOD), delivers high-quality semiconductor products to the world's leading companies in the automotive, industrial, computing, consumer electronics, and communications markets. We leverage our expanded product portfolio of analog and power solutions combined with a flexible hybrid manufacturing model that meet customers' needs. Our broad range of application-specific products, delivered through a total solutions sales approach and supported by global operations including engineering, testing, manufacturing, and customer service, enable us to be a premier provider for high-growth markets. For more information, visit www.diodes.com.

Safe Harbor Statement Under the Private Securities Litigation Reform Act of 1995: Any statements set forth above that are not historical facts are forward-looking statements that involve risks and uncertainties that could cause actual results to differ materially from those in the forward-looking statements. Such statements include statements containing forward-looking words such as "expect," "anticipate," "aim," "estimate," and variations thereof, including without limitation statements, whether direct or implied, regarding expectations of that for the second quarter of 2026, we expect revenue to be approximately \$435 million plus or minus 3 percent; we expect GAAP gross margin to be 32.8 percent, plus or minus 1 percent; and non-GAAP adjusted EPS to be \$0.60, plus or minus \$0.10. Potential risks and uncertainties include, but are not limited to, such factors as: the risk that such expectations may not be met; the risk that the expected benefits of acquisitions may not be realized or that integration of acquired businesses may not continue as rapidly as we anticipate; the risk that we may not be able to maintain our current growth strategy or continue to maintain our current performance, costs, and loadings in our manufacturing facilities; the risk that we may not be able to increase our automotive, industrial, or other revenue and market share; risks of domestic and foreign operations, including excessive operating costs, labor shortages, higher tax rates, and our joint venture prospects; the risks of cyclical downturns in the semiconductor industry and of changes in end-market demand or product mix that may affect gross margin or render inventory obsolete; the risk of unfavorable currency exchange rates; the risk that our future outlook or guidance may be incorrect; the risks of global economic weakness or instability in global financial markets; the risks of trade restrictions, tariffs, or embargoes; the risk of breaches of our information technology systems; and other information, including the "Risk Factors" detailed from time to time in Diodes' filings with the United States Securities and Exchange Commission.

The Diodes logo is a registered trademark of Diodes Incorporated in the United States and other countries. © 2026 Diodes Incorporated. All Rights Reserved.

Company Contact:

Diodes Incorporated
Gurmeet Dhaliwal
Vice President, Corporate Marketing & IR
P: 408-232-9003
E: Gurmeet_Dhaliwal@diodes.com

Investor Relations Contact:

Shelton Group
Leanne Sievers
President, Investor Relations
P: 949-224-3874
E: lsievers@sheltongroup.com

DIODES INCORPORATED AND SUBSIDIARIES
CONSOLIDATED CONDENSED STATEMENTS OF OPERATIONS
(in thousands, except per share data)

(unaudited)

	Three Months Ended March 31,	
	2026	2025
Net sales	\$ 405,467	\$ 332,113
Cost of goods sold	276,675	227,419
Gross profit	128,792	104,694
Operating expenses		
Selling, general, and administrative	64,305	58,699
Research and development	40,615	38,627
Amortization of acquisition related intangible assets	3,944	5,824
Loss (gain) on disposal of fixed assets	143	(18)
Other operating expense	20	266
Total operating expense	109,027	103,398
Income from operations	19,765	1,296
Other income (expense)		
Interest income	5,445	5,813
Interest expense	(682)	(467)
Foreign currency (loss), net	(3,377)	(183)
Unrealized gain (loss) on investments	2,450	(4,032)
Impairment of equity investments	(1,249)	(5,817)
Other income	91	617
Total other income (expense)	2,678	(4,069)
Income (loss) before income taxes, equity in net earnings of equity investments, and noncontrolling interest	22,443	(2,773)
Income tax provision	4,000	20
Equity in net earnings of equity investments	(2,341)	6
Net income/(loss)	16,102	(2,787)
Less net income attributable to noncontrolling interest	(1,141)	(1,650)
Net income (loss) attributable to common stockholders	\$ 14,961	\$ (4,437)
Earnings (loss) per share attributable to common stockholders:		
Basic	\$ 0.33	\$ (0.10)
Diluted	\$ 0.32	\$ (0.10)
Number of shares used in earnings per share computation:		
Basic	45,919	46,370
Diluted	46,138	46,370

Note: Throughout this release, we refer to “net income attributable to common stockholders” as “net income.”

DIODES INCORPORATED AND SUBSIDIARIES
RECONCILIATION OF NET INCOME TO ADJUSTED NET INCOME
(in thousands, except per share data)
(unaudited)

For the three months ended March 31, 2026:

	<u>Operating Expenses</u>	<u>Other (Income) Expense</u>	<u>Income Tax Provision</u>	<u>Net Income</u>
Per-GAAP net income				\$ 14,961
Diluted earnings per share (per-GAAP)				\$ 0.32
Adjustments to reconcile net income to non-GAAP net income:				
Amortization of acquisition-related intangible assets	3,944		(709)	3,235
Board member/Officer retirement	1,149		(287)	862
Gain/Loss on Investments		1,140	(407)	733
Non-GAAP adjusted net income				\$ 19,791
Diluted shares used in computing earnings per share				46,138
Non-GAAP diluted earnings per share				\$ 0.43

Note: Included in GAAP net income and non-GAAP adjusted net income was approximately \$6.0 million, net of tax, non-cash share-based compensation expense. Excluding share-based compensation expense, both GAAP and non-GAAP diluted earnings per share would have improved by \$0.13 per share.

DIODES INCORPORATED AND SUBSIDIARIES
CONSOLIDATED RECONCILIATION OF NET INCOME TO ADJUSTED NET INCOME – Cont.
(in thousands, except per share data)
(unaudited)

For the three months ended March 31, 2025:

	<u>Operating Expenses</u>	<u>Other (Income) Expense</u>	<u>Income Tax Provision</u>	<u>Net Income</u>
Per-GAAP net loss				\$ (4,437)
Diluted Loss per share(GAAP)				\$ (0.10)
Adjustments to reconcile net (loss) to non-GAAP net income:				
Amortization of acquisition-related intangible assets	5,824		(1,031)	4,793
Acquisition related cost	171		(36)	135
Restructuring charge	266		(40)	226
Impairment of equity investment		5,817	(968)	4,849
Non-cash mark-to-market investment value adjustments		4,032	(806)	3,226
Non-GAAP adjusted net income				\$ 8,792
Diluted shares used in computing earnings per share				46,440
Non-GAAP diluted earnings per share				\$ 0.19

Note: Included in GAAP net income and non-GAAP adjusted net income was approximately \$5.0 million, net of tax, non-cash share-based compensation expense. Excluding share-based compensation expense, both GAAP and non-GAAP diluted earnings per share would have improved by \$0.11 per share.

ADJUSTED NET INCOME AND ADJUSTED EARNINGS PER SHARE

The Company's financial statements present net income and earnings per share that are calculated using accounting principles generally accepted in the United States ("GAAP"). The Company's management makes adjustments to the GAAP measures that it feels are necessary to allow investors and other readers of the Company's financial releases to view the Company's operating results as viewed by the Company's management, board of directors and research analysts in the semiconductor industry. These non-GAAP measures are not prepared in accordance with, and should not be considered alternatives or necessarily superior to, GAAP financial data and may be different from non-GAAP measures used by other companies. Because non-GAAP financial measures are not standardized, it may not be possible to compare these financial measures with other companies' non-GAAP financial measures, even if they have similar names. The explanation of the adjustments made in the table above, are set forth below:

Detail of non-GAAP adjustments

Amortization of acquisition-related intangible assets – The Company excluded this item, including amortization of developed technologies and customer relationships. The fair value of the acquisition-related intangible assets is amortized using straight-line methods which approximate the proportion of future cash flows estimated to be generated each period over the estimated useful life of the applicable assets. The Company believes that exclusion of this item is appropriate because a significant portion of the purchase price for its acquisitions was allocated to the intangible assets that have short lives and exclusion of the amortization expense allows comparisons of operating results that are consistent over time for both the Company's newly acquired and long-held businesses. In addition, the Company excluded this item because there is significant variability and unpredictability among companies with respect to this expense.

Board member / Officer retirement – The Company excluded costs related to (1) the retirement of a board member, these costs represent cash payments and the accelerated vesting of previously issued stock awards, (2) the retirement of an officer, these costs represent cash payments and the accelerated vesting of previously issued stock awards. The Company feels it is appropriate to exclude these costs since they don't represent ongoing operating expenses and will present investors with a more accurate indication of our continuing operations.

Acquisition related costs – The Company excluded expenses associated with previous acquisitions of that typically consist of advisory, legal and other professional and consulting fees. These costs were expensed as they were incurred and as services were received, and in which the corresponding tax adjustments were made for the non-deductible portions of these expenses. The Company believes the exclusion of the acquisition-related costs provides investors with a more accurate reflection of costs likely to be incurred in the absence of an unusual event such as an acquisition and facilitates comparisons with the results of other periods that may not reflect such costs.

Restructuring charge – The Company recorded restructuring charges related to various locations. These restructuring charges are excluded from management's assessment of the Company's operating performance. The Company believes the exclusion of the restructuring charges provides investors an enhanced view of the cost structure of the Company's operations and facilitates comparisons with the results of other periods that may not reflect such charges or may reflect different levels of such charges.

Gain/Loss on Investment – The Company excluded gains and losses on various investments. The Company believes these amounts are not reflective of the ongoing operations of the Company and exclusion of these items, provides investors an enhanced view of the Company's operating results.

Non-cash mark-to-market investment adjustments – The Company excluded mark-to-market adjustments on various equity related investments. The Company believes this is not reflective of the ongoing operations and exclusion of this provides investors an enhanced view of the Company's operating results.

Impairment of equity investment – The Company excluded the impairment on equity investment. The Company believes this is not reflective of the ongoing operations and exclusion of this item provides investors an enhanced view of the Company's operating results.

CASH FLOW ITEMS

Free cash flow (FCF) (Non-GAAP)

FCF for the first quarter of 2026 is a non-GAAP financial measure, which is calculated by subtracting capital expenditures from cash flow from operations. For the first quarter of 2026, FCF was \$32.4 million, which represents the cash and cash equivalents that we are able to generate after taking into account cash outlays required to maintain or expand property, plant and equipment. FCF is important because it allows us to pursue opportunities to develop new products, make acquisitions and reduce debt.

CONSOLIDATED RECONCILIATION OF NET INCOME TO EBITDA

EBITDA represents earnings before net interest expense, income tax provision, depreciation and amortization. Management believes EBITDA is useful to investors because it is frequently used by securities analysts, investors and other interested parties, such as financial institutions in extending credit, in evaluating companies in our industry and provides further clarity on our profitability. In addition, management uses EBITDA, along with other GAAP and non-GAAP measures, in evaluating our operating performance compared to that of other companies in our industry. The calculation of EBITDA generally eliminates the effects of financing, operating in different income tax jurisdictions, and accounting effects of capital spending, including the impact of our asset base, which can differ depending on the book value of assets and the accounting methods used to compute depreciation and amortization expense. EBITDA is not a recognized measurement under GAAP, and when analyzing our operating performance, investors should use EBITDA in addition to, and not as an alternative for, income from operations and net income, each as determined in accordance with GAAP. Because not all companies use identical calculations, our presentation of EBITDA may not be comparable to similarly titled measures used by other companies. For example, our EBITDA takes into account all net interest expense, income tax provision, depreciation and amortization without taking into account any amounts attributable to noncontrolling interest. Furthermore, EBITDA is not intended to be a measure of free cash flow for management's discretionary use, as it does not consider certain cash requirements such as tax and debt service payments.

The following table provides a reconciliation of net income to EBITDA (*in thousands, unaudited*):

	Three Months Ended	
	March 31,	
	2026	2025
Net income (loss) (per-GAAP)	\$ 14,961	\$ (4,437)
Plus:		
Interest expense, net	(4,763)	(5,346)
Income tax provision	4,000	20
Depreciation and amortization	35,212	35,918
EBITDA (non-GAAP)	\$ 49,410	\$ 26,155

DIODES INCORPORATED AND SUBSIDIARIES
CONSOLIDATED CONDENSED BALANCE SHEETS
(In thousands, except per share data)
(Unaudited)

	March 31, 2026	December 31, 2025
Assets		
Current assets:		
Cash and cash equivalents	\$ 394,062	\$ 367,212
Restricted cash	5,144	5,134
Short-term investments	10,188	9,817
Accounts receivable, net of allowances of \$3,959 and \$4,095, respectively	304,461	307,055
Inventories	492,761	471,546
Prepaid expenses and other	96,057	96,198
Total current assets	1,302,673	1,256,962
Property, plant, and equipment, net	652,202	649,605
Deferred tax assets	58,287	59,297
Goodwill	182,288	183,437
Intangible assets, net	41,425	45,455
Equity investments	154,656	156,272
Operating lease assets	48,636	38,740
Other long-term assets	57,561	58,332
Total assets	\$ 2,497,728	\$ 2,448,100
Liabilities		
Current liabilities:		
Line of credit	\$ 30,047	\$ 30,264
Accounts payable	169,198	149,376
Operating lease liabilities, current	12,124	10,666
Accrued liabilities and other	179,591	170,256
Income tax payable	18,771	16,336
Current portion of long-term debt	1,635	1,442
Total current liabilities	411,366	378,340
Long-term debt, net of current portion	23,704	24,224
Deferred tax liabilities	4,859	6,145
Unrecognized tax benefits	23,629	23,454
Operating lease liabilities	37,368	28,890
Other long-term liabilities	45,933	48,638
Total liabilities	546,859	509,691
Stockholders' equity		
Preferred stock - par value \$1.00 per share; 1,000 shares authorized; no shares issued or outstanding	-	-
Common stock - par value \$0.66 2/3 per share; 70,000 shares authorized; 55,948 and 55,883 issued; 45,940 and 45,875 outstanding, respectively	37,303	37,259
Additional paid-in capital	544,117	538,087
Retained earnings	1,800,400	1,785,439
Treasury stock, at cost, 10,008 shares	(372,109)	(371,914)
Accumulated other comprehensive loss	(120,305)	(110,747)
Stockholders' equity	1,889,406	1,878,124
Noncontrolling interest	61,463	60,285
Total equity	1,950,869	1,938,409
Total liabilities and stockholders' equity	\$ 2,497,728	\$ 2,448,100



Analog & Power
Solutions

Exhibit 99.2

FIRST QUARTER 2026 FINANCIAL RESULTS

Diodes Incorporated (DIOD)

May 7, 2026

diodes.com



Safe Harbor Statement Under the Private Securities Litigation Reform Act of 1995: Any statements set forth above that are not historical facts are forward-looking statements that involve risks and uncertainties that could cause actual results to differ materially from those in the forward-looking statements. Such statements include statements containing forward-looking words such as “expect,” “anticipate,” “aim,” “estimate,” and variations thereof, including without limitation statements, whether direct or implied, regarding expectations of that for the second quarter of 2026, we expect revenue to be approximately \$435 million plus or minus 3 percent; we expect GAAP gross margin to be 32.8 percent, plus or minus 1 percent; and non-GAAP adjusted EPS to be \$0.60, plus or minus \$0.10. Potential risks and uncertainties include, but are not limited to, such factors as: the risk that such expectations may not be met; the risk that the expected benefits of acquisitions may not be realized or that integration of acquired businesses may not continue as rapidly as we anticipate; the risk that we may not be able to maintain our current growth strategy or continue to maintain our current performance, costs, and loadings in our manufacturing facilities; the risk that we may not be able to increase our automotive, industrial, or other revenue and market share; risks of domestic and foreign operations, including excessive operating costs, labor shortages, higher tax rates, and our joint venture prospects; the risks of cyclical downturns in the semiconductor industry and of changes in end-market demand or product mix that may affect gross margin or render inventory obsolete; the risk of unfavorable currency exchange rates; the risk that our future outlook or guidance may be incorrect; the risks of global economic weakness or instability in global financial markets; the risks of trade restrictions, tariffs, or embargoes; the risk of breaches of our information technology systems; and other information, including the “Risk Factors” detailed from time to time in Diodes’ filings with the United States Securities and Exchange Commission.

This presentation also contains non-GAAP measures. See the Company’s press release on May 7, 2026, titled, “Diodes Incorporated Reports First Quarter 2026 Financial Results” for detailed information related to the Company’s non-GAAP measures and a reconciliation of GAAP net income to non-GAAP net income.

Diodes delivers analog and power solutions through its high-quality semiconductor products to the world's leading companies in the automotive, industrial, computing, consumer electronics, and communications markets.

FY 2025

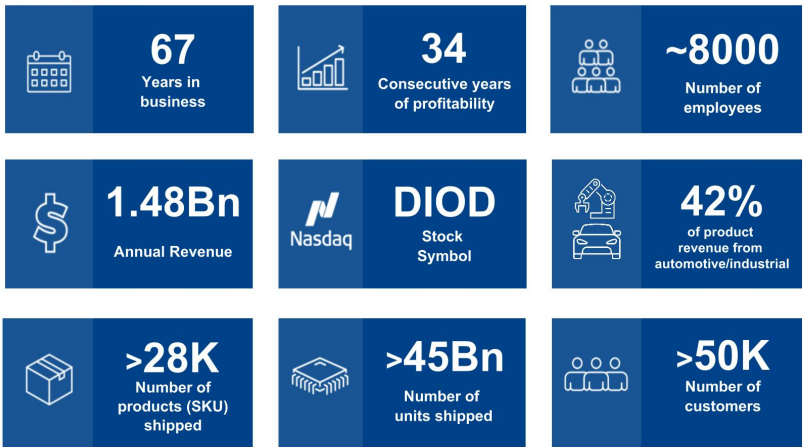

Vision:
Inspire future technology through leading semiconductor solutions

Our Core Values:
Integrity,
Commitment,
Innovation

3-Year Targets (2028):

\$2B Revenue
Gross Profit: \$700M
Gross Margin: 35%+
Non-GAAP EPS: \$4.00+



Analog & Power Solutions

Track Record of Continued Performance

Annual Revenue

(\$ in millions)



Gross Profit

(\$ in millions)

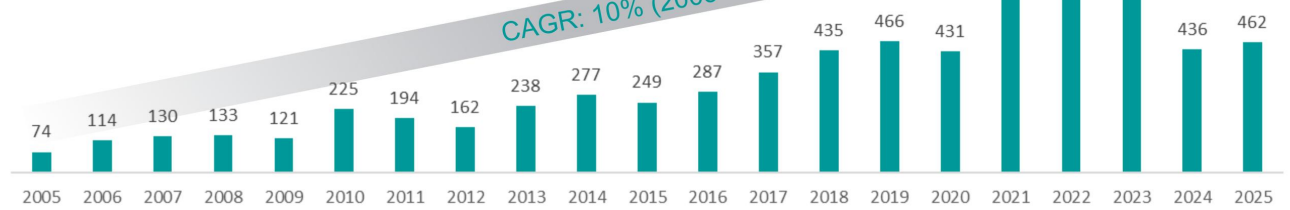

Analog & Power Solutions

44% of
revenue
(Q1 2026)

Automotive

- Connected driving, comfort/style/safety, electrification/powertrain

Industrial

- Embedded systems, industrial automation, medical, energy management, smart buildings

56% of
revenue
(Q1 2026)

Computing

- AI data center including AI server, storage, and edge AI

Consumer

- IoT: wearables, home automation, home appliances, and charging solutions

Communications

- Smart phones, telecom, enterprise networking, smart infrastructure including space-based connectivity



Analog & Power
Solutions

Revenue \$405.5M +3.5% Q-Q	GAAP Gross Profit \$128.8M + 5.7% Q-Q	GAAP Gross Margin 31.8% +70 bps Q-Q	Non-GAAP EPS \$0.43 +26.5% Q-Q
Non-GAAP Net Income \$19.8M +26.1% Q-Q	EBITDA \$49.4M 12.2% of Revenue	Cash Flow from Ops \$64.3M 15.9% of Revenue	Strong Balance Sheet \$409M/\$55M Cash*/Debt



1Q revenue achieved over 22% YoY growth and an above seasonal 3.5% QoQ increase



Growth driven by key focus areas of automotive, industrial and AI-server related applications



Automotive and industrial increased to 44% of product revenue



Strong balance sheet with \$409 million in cash and cash equivalents*; \$891 million working capital



At the mid-point of guidance 2Q 2026 revenue to increase 18.8% YoY and a 7.3% increase QoQ



Analog & Power Solutions

* Cash and cash equivalents, restricted cash, and short-term investments

Revenue (\$ Millions)

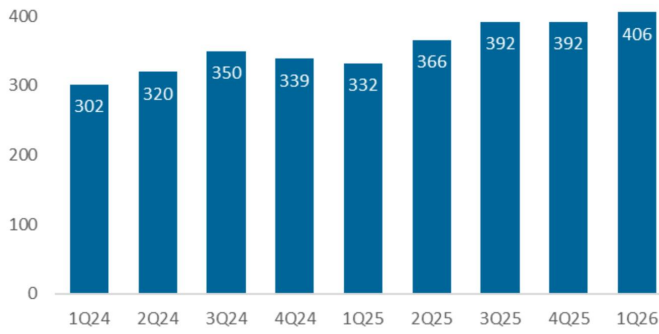

Gross Profit (\$ Millions)

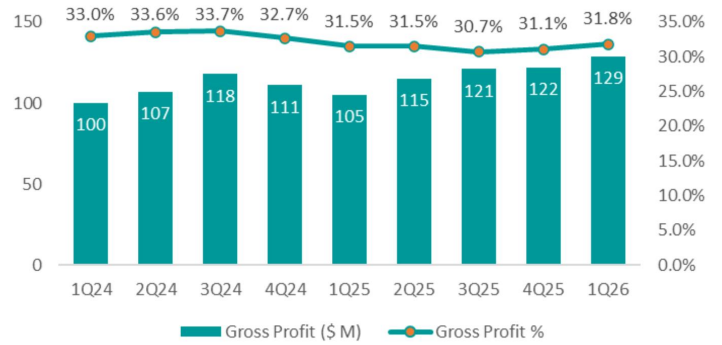

- 1Q revenue increased 22% year-over-year
- Fifth consecutive quarter of double-digit YoY growth
- Growth driven by 32% year-over-year increases in automotive and 31% year-over-year increase in industrial

- Future margin expansion will be driven by increasing contribution from higher-margin automotive, industrial, and data center end markets, new products as well as improved loading across manufacturing facilities

By Channel

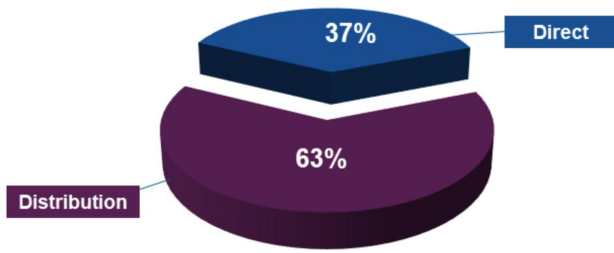

By Region

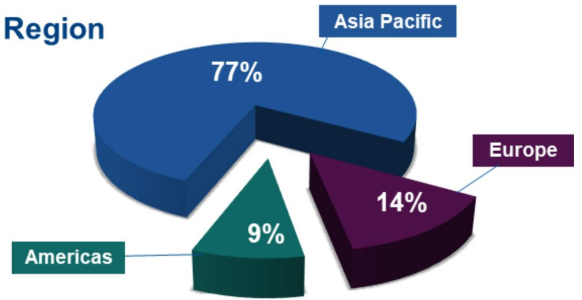

By End Market

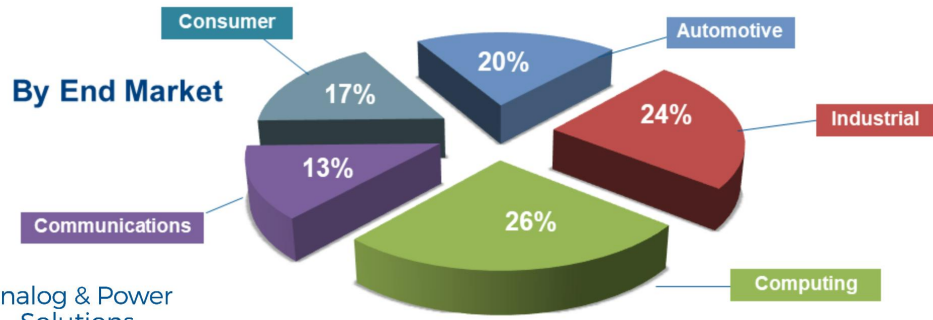

Analog & Power Solutions

(\$ in millions, except EPS)	1Q25	4Q25	1Q26
Net sales	332.1	391.6	405.5
Gross profit (GAAP)	104.7	121.9	128.8
Gross profit margin % (GAAP)	31.5%	31.1%	31.8%
Net income (GAAP)	(4.4)	10.2	15.0
Net income (non-GAAP)	8.8	15.4	19.8
Diluted EPS (non-GAAP)	0.19	0.34	0.43
Cash flow from operations	56.7	38.1	64.3
EBITDA (non-GAAP)	26.2	41.9	49.4



Analog & Power
Solutions

(\$ in millions)	Dec 31, 2024	Dec 31, 2025	Mar 31, 2026
Cash*	322	382	409
Inventory	475	472	493
Current assets	1,224	1,257	1,303
Total assets	2,386	2,448	2,498
Total debt	52	56	55
Total liabilities	517	510	547
Total equity	1,869	1,938	1,951

*Cash and cash equivalents, restricted cash, and short-term investments



Analog & Power
Solutions

- Revenue to be ~\$435 million, +/- 3.0%
representing 18.8% growth over the prior year period and a 7.3% increase sequentially at the mid-point, which is significantly better than typical seasonality
- GAAP gross margin of 32.8%, +/- 1%
- Non-GAAP adjusted EPS is expected to be \$0.60, plus or minus \$0.10

Vision:

- Inspire future technology through leading semiconductor solutions.

Mission:

- Deliver profitability growth through advanced analog and power solutions that enable innovation and efficiency across high-growth markets.

3-year Target : \$2B revenue and \$4+ non-GAAP EPS**Strategic Priorities:**

- Drive growth through a total system solutions sales approach and expanded solution-oriented content
- Deepen focus on key accounts to increase share of wallet
- Prioritize high-margin markets, including automotive, industrial, data center through analog & power solutions
- Invest in technology leadership across target products, fab processes, and advanced packaging
- Accelerate fab process and product qualifications



Analog & Power
Solutions



Analog & Power
Solutions

THANK YOU

diodes.com

*Inspiring future technology through
leading semiconductor solutions*

Reconciliation of Net Income to Adjusted Net Income

15

For the three months ended March 31, 2026

(in thousands, except per share data)
(unaudited)

	Operating Expenses	Other (Income) Expense	Income Tax Provision	Net Income
Per-GAAP net income				\$ 14,961
Diluted earnings per share (per-GAAP)				\$ 0.32
Adjustments to reconcile net income to non-GAAP net income:				
Amortization of acquisition-related intangible assets	3,944		(709)	3,235
Board member/ Officer retirement	1,149		(287)	862
Gain/ Loss on Investments		1,140	(407)	733
Non-GAAP adjusted net income				\$ 19,791
Diluted shares used in computing earnings per share				46,138
Non-GAAP diluted earnings per share				\$ 0.43

Note: Included in GAAP net income and non-GAAP adjusted net income was approximately \$6.0 million, net of tax, non-cash share-based compensation expense. Excluding share-based compensation expense, both GAAP and non-GAAP diluted earnings per share would have improved by \$0.13 per share.



Analog & Power
Solutions

For the three months ended March 31, 2025

*(in thousands, except per share data)
(unaudited)*

	Operating Expenses	Other (Income) Expense	Income Tax Provision	Net Income
Per-GAAP				\$ (4,437)
Loss per share (GAAP)				\$ (0.10)
Adjustments to reconcile net (loss) to non-GAAP net income:				
Amortization of acquisition-related intangible assets	5,824		(1,031)	4,793
Acquisition related cost	171		(36)	135
Restructuring charge	266		(40)	226
Impairment of equity investment		5,817	(968)	4,849
Non-cash mark-to-market investment value adjustments		4,032	(806)	3,226
Non-GAAP				\$ 8,792
Diluted shares used in computing earnings per share				46,440
Non-GAAP diluted earnings per share				\$ 0.19

Note: Included in GAAP net income and non-GAAP adjusted net income was approximately \$5.0 million, net of tax, non-cash share-based compensation expense. Excluding share-based compensation expense, both GAAP and non-GAAP diluted earnings per share would have improved by \$0.11 per share.



Analog & Power
Solutions

INVESTOR RELATIONS

Diodes Incorporated (DIOD)

May 7, 2026

diodes.com



Safe Harbor Statement Under the Private Securities Litigation Reform Act of 1995: Any statements set forth above that are not historical facts are forward-looking statements that involve risks and uncertainties that could cause actual results to differ materially from those in the forward-looking statements. Such statements include statements containing forward-looking words such as “expect,” “anticipate,” “aim,” “estimate,” and variations thereof, including without limitation statements, whether direct or implied, regarding expectations of that for the second quarter of 2026, we expect revenue to be approximately \$435 million plus or minus 3 percent; we expect GAAP gross margin to be 32.8 percent, plus or minus 1 percent; and non-GAAP adjusted EPS to be \$0.60, plus or minus \$0.10. Potential risks and uncertainties include, but are not limited to, such factors as: the risk that such expectations may not be met; the risk that the expected benefits of acquisitions may not be realized or that integration of acquired businesses may not continue as rapidly as we anticipate; the risk that we may not be able to maintain our current growth strategy or continue to maintain our current performance, costs, and loadings in our manufacturing facilities; the risk that we may not be able to increase our automotive, industrial, or other revenue and market share; risks of domestic and foreign operations, including excessive operating costs, labor shortages, higher tax rates, and our joint venture prospects; the risks of cyclical downturns in the semiconductor industry and of changes in end-market demand or product mix that may affect gross margin or render inventory obsolete; the risk of unfavorable currency exchange rates; the risk that our future outlook or guidance may be incorrect; the risks of global economic weakness or instability in global financial markets; the risks of trade restrictions, tariffs, or embargoes; the risk of breaches of our information technology systems; and other information, including the “Risk Factors” detailed from time to time in Diodes’ filings with the United States Securities and Exchange Commission.

This presentation also contains non-GAAP measures. See the Company’s press release on May 7, 2026, titled, “Diodes Incorporated Reports First Quarter 2026 Financial Results” for detailed information related to the Company’s non-GAAP measures and a reconciliation of GAAP net income to non-GAAP net income.

Gary Yu

President and CEO

Experience:

- Diodes Incorporated, since 2008
 - Chief Operating Officer
 - Senior Vice President, Business Groups
 - President, Asia Pacific Region
 - General Manager, Shanghai Wafer Fabrication and BCD Business Unit
 - Vice President of Asia Pacific Sales
 - Manager, Sensor and Satellite Business Unit
- Lite-On Semiconductor Corporation
 - Vice President, Worldwide Sales
- Texas Instruments
 - IT, Finance and Capacity Planning

Education:

- MBA – University of Dallas
- Master's Degree in Telecommunication Engineering, Southern Methodist University
- Bachelor's Degree in MIS, Fu-Jen University, Taiwan



Analogue & Power
Solutions

Gurmeet Dhaliwal

VP, Corporate Marketing & Investor Relations

Experience:

- Head of Corporate Marketing, Diodes Incorporated
- Head of Corporate Marketing, Pericom Semiconductor
- Vice President, Marketing, CA Technologies (Broadcom)
- Director, Global Marketing Strategy, EMC (Dell Technologies)
- Director, Marketing, Zarlink Semiconductor (Microchip)
- Marketing Management positions at Cisco and National Semiconductor (TI)

Education:

- MBA, Marketing/Entrepreneurship, Saint Mary's College of California
- BS in Electrical and Computer Engineering, UC Santa Barbara



Analog & Power
Solutions

Diodes delivers analog and power solutions through its high-quality semiconductor products to the world's leading companies in the automotive, industrial, computing, consumer electronics, and communications markets.

FY 2025

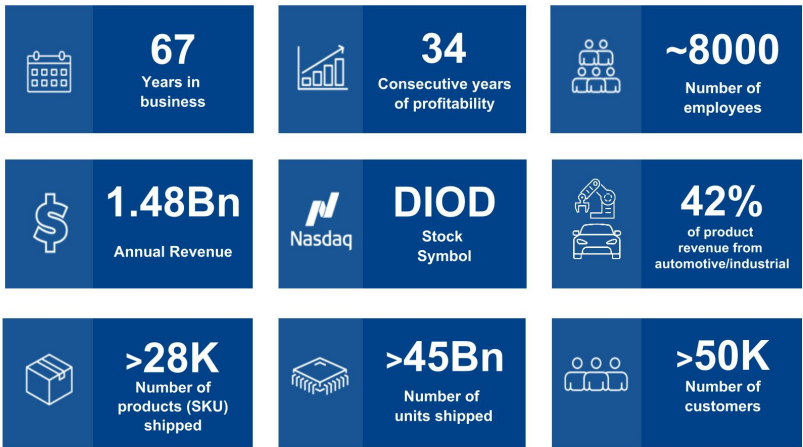

Vision:
Inspire future technology through leading semiconductor solutions

Our Core Values:
Integrity,
Commitment,
Innovation

Global Operations and World-Class Manufacturing

- Headquartered in Plano, TX
- Manufacturing in US, UK, Germany, China, and Taiwan
- ISO 9001:2015 Certified / IATF 16949:2016 Certified
- ISO 14001:2015 Certified



Key Acquisitions

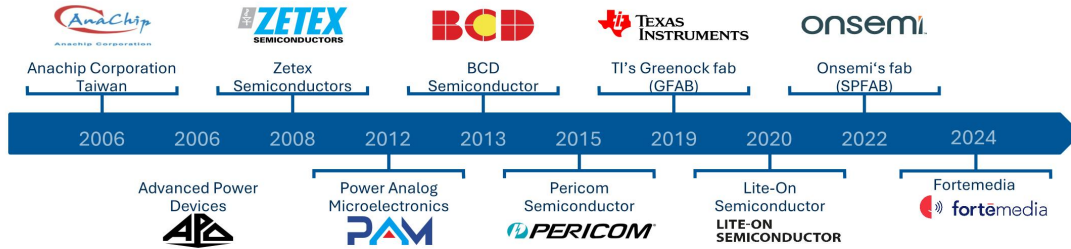



Our commitment to a sustainable and profitable business is built around ESG.



3-Year Targets (2028):

\$2B Revenue
Gross Profit: \$700M
Gross Margin: 35%+
Non-GAAP EPS: \$4.00+



- Goal 4: \$1B Profit Before Tax
- Goal 3: \$2.5B Revenue
\$1B Gross Profit (40% GM)
- ✓ Goal 2: \$1B Revenue- 2017
- ✓ Goal 1: \$1B Market Cap - 2010



Analog & Power
Solutions

Track Record of Continued Performance

Annual Revenue

(\$ in millions)



Gross Profit

(\$ in millions)

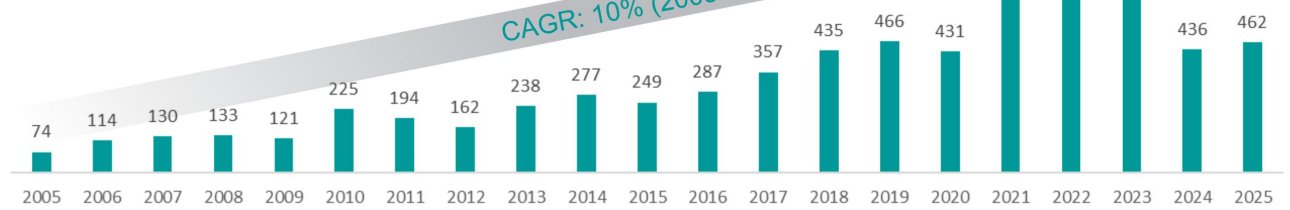

Analog & Power Solutions

44% of
revenue
(Q1 2026)

Automotive

- Connected driving, comfort/style/safety, electrification/powertrain

Industrial

- Embedded systems, industrial automation, medical, energy management, smart buildings

56% of
revenue
(Q1 2026)

Computing

- AI data center including AI server, storage, and edge AI

Consumer

- IoT: wearables, home automation, home appliances, and charging solutions

Communications

- Smart phones, telecom, enterprise networking, smart infrastructure including space-based connectivity



Analog & Power
Solutions

Capability up to:
 32Gbps PCIe® 5.0
 24Gbps SAS-4
 20Gbps USB 3.2/USB4
 20Gbps Thunderbolt™ 4
 20Gbps DisplayPort™ 2.1
 12Gbps HDMI™ 2.1 10Gbps Ethernet
 6Gbps SATA 3.0
 2.5Gbps MIPI D-PHY 1.2

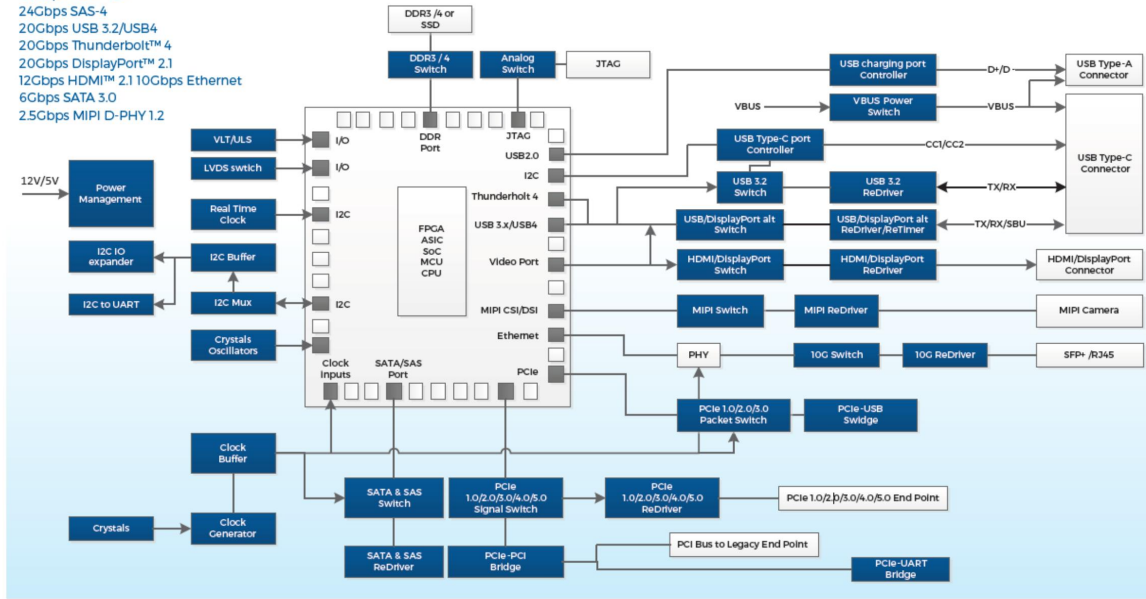

Analog & Power Solutions

Example: Embedded System Applications

Focus Applications:

Connected Driving

- ADAS (Advanced Driver Assistance Systems)
- Telematics
- Infotainment Systems

Comfort, Style, and Safety

- Lighting
 - Migration to LED and intelligent illumination
- BLDC motor / fan control
 - Migration from Brushed to Brushless DC Motors

Electrification/Powertrain

- Conventional Powertrain → Hybrid → Electrification
- Battery management
 - Move to 48V battery

Automotive Revenue Growth

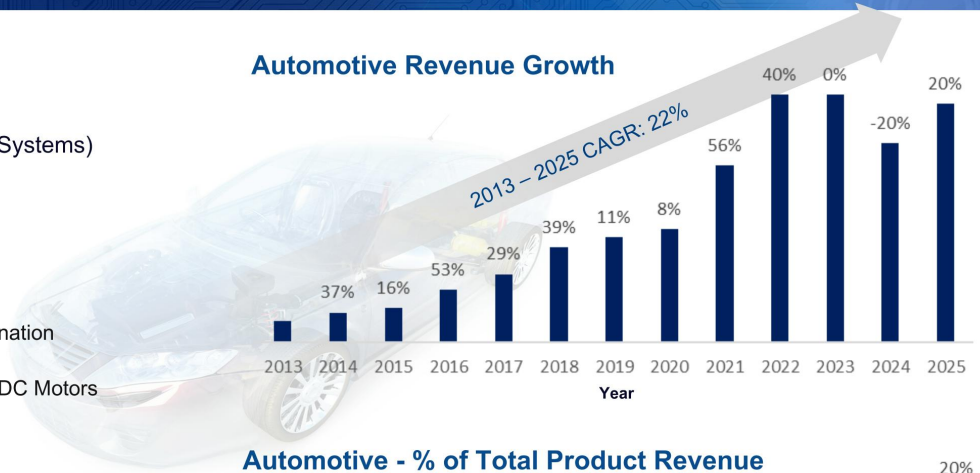

Automotive - % of Total Product Revenue



Analog & Power Solutions

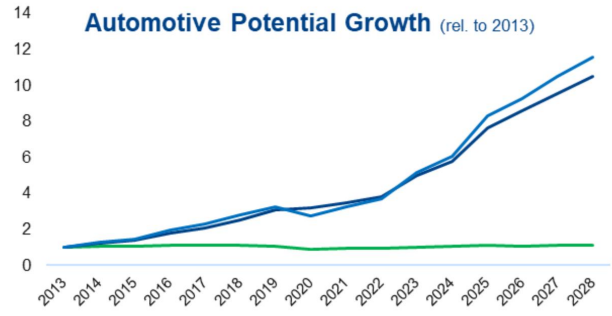
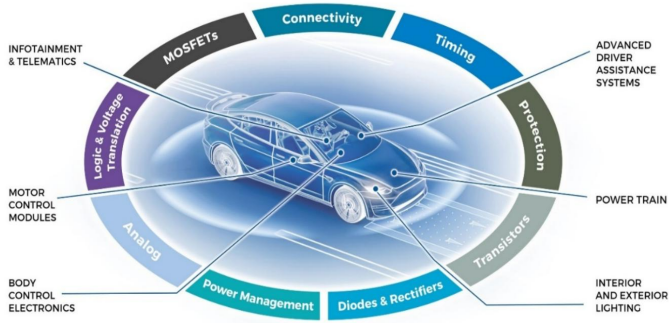

Automotive Potential Revenue	\$ / Car
Automotive Motor Control	\$56.00
Connected Driving (Infotainment, Telematics & ADAS)	\$100.00
Powertrain, Electrification & Body Control Electronics	\$60.00
Lighting – Moving to LED	\$23.00
Total	\$239.00

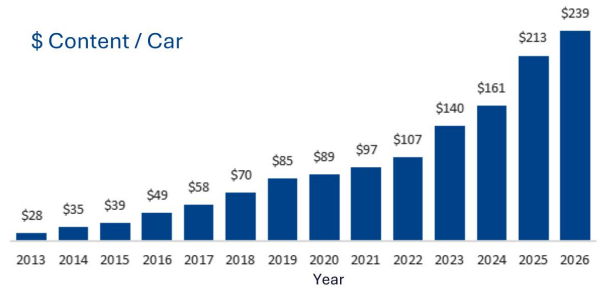

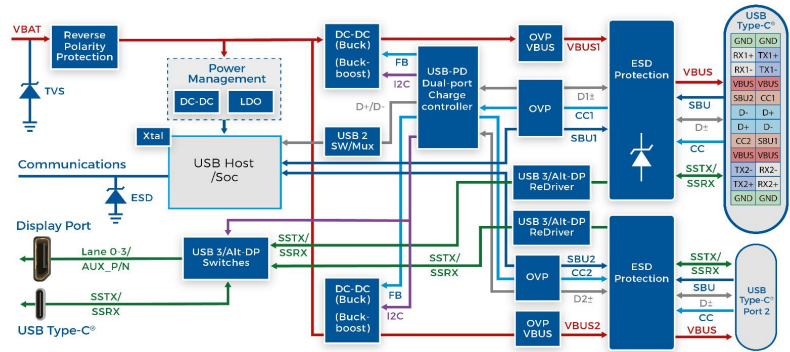

Diodes' Key Products	\$ / per car
Power Management	\$6.20
MOS/BJT	\$2.50
Diodes and Rectifiers	\$1.00
Timing and Connectivity	\$5.00
Total	\$14.70

USB-C charging is a high-growth application with 2 to 8 ports per vehicle.

- USB PD is an important expansion capability → up to 100W/port → growing to 140+W
- USB-C supports DP over USB and opens the opportunity to share portable equipment screens on an interior display → growing YoY

Diodes provides a USB charging solution for both Power and Data which includes:

- Port Controllers, USB Muxes, Signal Switches, ReDrivers, Xtals, Power Management, and Protection (Powerline and Dataline).

Automotive-compliant* product portfolio growth is expanding the SAM further.



Analog & Power Solutions

Automotive compliant (Q) - AEC-Qualified, in manufacturing sites certified to IATF 16949 supporting PPAP

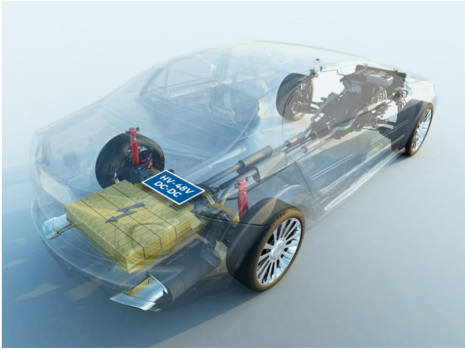

Diodes' Key Products	\$ / per car
Amplifier and Sensor	\$0.25
Power Management	\$1.20
MOS/BJT	\$21.00
Diodes and Rectifiers	\$0.15
Total	\$23.60

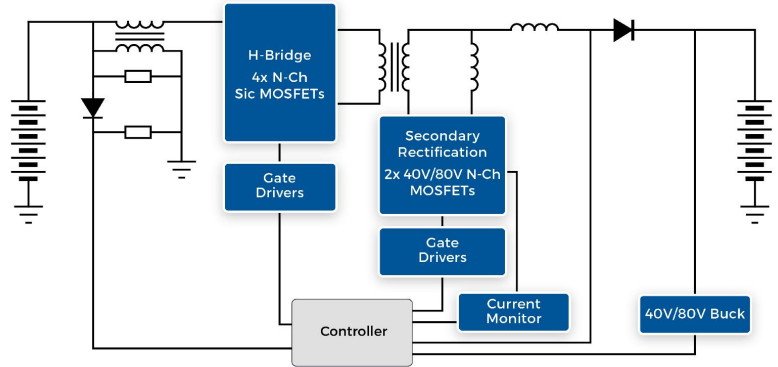

xEVs create the need for high-efficiency conversion of high-voltage batteries to lower, safe voltages.

- Converts high-voltage DC (300V to 900V) to a galvanically isolated 48V or 12V DC rail
- 48V Battery/Rail creates opportunity for 48V:12V conversion

Diodes' automotive-compliant* product solutions contain:

- Silicon carbide and silicon MOSFETs, isolated (RobustISO) gate drivers, current monitors, and 80V high-performance buck converters



Analog & Power Solutions

Automotive compliant (Q) - AEC-Qualified, in manufacturing sites certified to IATF 16949 supporting PPAP

Focus on key growing industrial sectors

Energy Management

- Energy efficiency is always the target
- Diodes supports
 - Isolated products, High voltage DCDC, SiC MOSFETs and Diodes

Industrial Automation

- Driven by moves to AI and robotics
- Demand for increased operational efficiency
- Diodes supports
 - Timing and Connectivity, MOSFETs, Protection and Sensing

Smart Buildings

- Energy efficiency and improved security demands
- Diodes supports
 - LED drivers, MOSFETs, Gate drivers, Signal conditioning

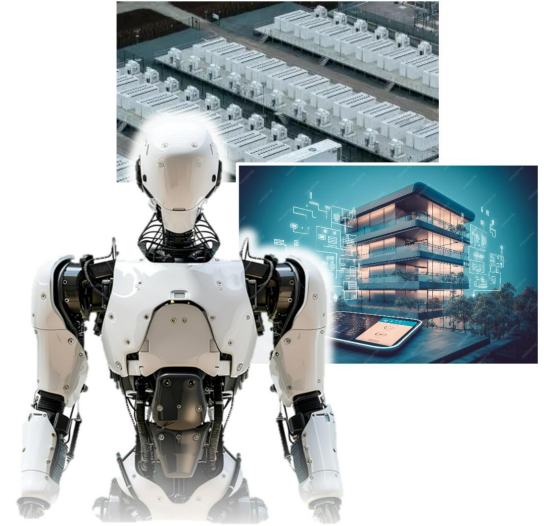

Analog & Power
Solutions

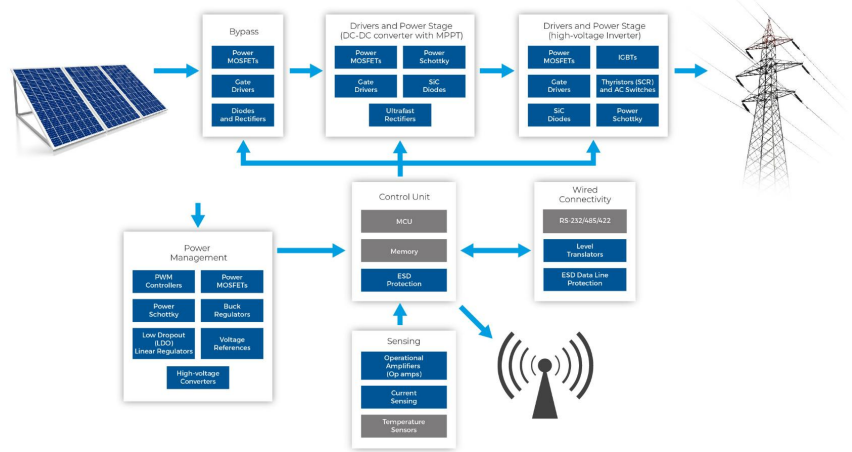

Diodes' Key Products	\$ / per unit	
	Microinverter (500W)	String Inverter (3kW)
MOS	\$8.40	\$17.50
SiC	\$15.00	\$26.20
Power Management	\$4.80	\$9.60
Analog	\$6.40	\$8.00
Total	\$36.40	\$61.30
\$ / per kW	\$69.20 / kW	\$20.40 / kW

- Solar inverters are a high-growth segment driven by residential and commercial PV adoption.
- Diodes provides a system solution for solar inverters including MOSFETs, SiC devices, Gate Drivers, Power Management ICs, and Analog components for sensing and protection.

Diode's Solution Advantage

- **Power Management Solutions** offer the most efficient power tree to extend battery life and provide clean power rails for sensors and digital processing
- **MOSFET Solutions** provide efficient drive of the motors reducing wasted energy with lower temperatures
- **High Performance Interface Solutions** offer high-speed sensor data backbone connectivity
- **Precision Timing Solutions** generate and distribute low noise, high frequency digital clock signals to AI Processors and data busses



3 Phase Bionic Joint Motor

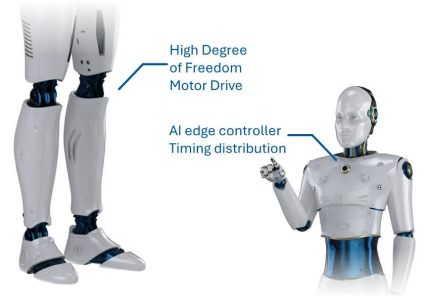

Diodes' Key Products	\$ / Bot
Amplifiers and Sensors	\$2.00
Power Management	\$3.50
MOSFET / BJT	\$9.50
Diodes and Rectifiers	\$1.00
Timing and Connectivity	\$10.00
Total	\$26.00

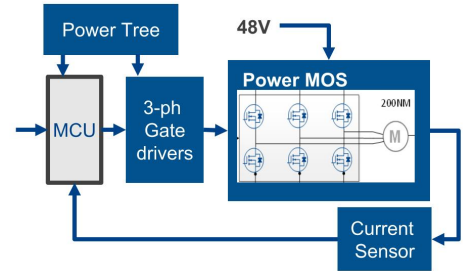
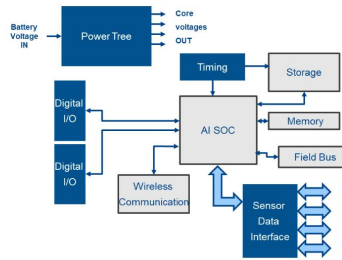

- Focused on power management solutions, timing tree, and connectivity
- Power management solutions: LDOs, DCDC, SBR, MOSFET and TVS for power management and protection
- Timing solutions to support increasing clocking speeds and challenge jitter requirement
- Connectivity for PCIe, CXL, SAS, SATA, USB
 - ReDriver for improving signal integrity
 - MUX/DeMUX for flexibility and saving pin counts
 - Packet switches for accelerating AI computing



Server Platform Solution:

- Broad portfolio in power management – analog and discrete
- Complete timing solutions, from crystals, Oscillators, clock generators and clock buffers, meet jitter performance of PCIe Gen7
- Improve signal integrity and flexibility

Diodes' Key Products	\$ / Box
Analog	\$7.00
Power Management	\$8.00
MOS/BJT	\$14.3
Timing and Connectivity	\$73.7
Total*	\$103.00

* 14% increase from last year

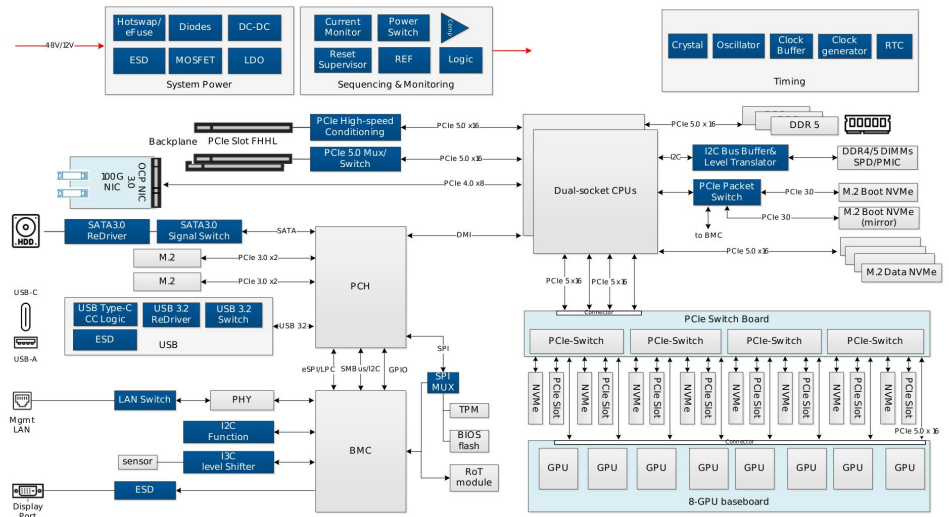



Lifestyle



Consumer & Home



Wearables



Asset Tracking



Retail



Security & Surveillance



Diodes' Key Products	\$ / Box
Analog	>\$0.20
Power Management	>\$1.30
MOS/BJT	>\$10.00
Diodes and Rectifiers	>\$5.00
Timing and Connectivity	\$3.50
Total	\$20.00

Growth Opportunities:

- Power
- LED drivers
- Xtals and clocks
- Packet switches

Focus Applications:

Cloud Computing

- Data Center Network Switches

Gateways

- Internet gateways
- Fiber networks
- Space-Based Connectivity

Core Networks, Cell Stations

- Small cells
- Base stations
- Edge computing servers
- Smart antennas
- Fiber networks

End Products

- Portables: smartphones, tablets
- Smart cars
- Consumer: VR/AR/MR, drones, IoT
- Telecom: 5G CPEs
- Embedded / industrial



Network Switch Solution:

- Complete timing solutions, from crystals, Oscillators, clock generators and clock buffers, to support every need of a timing tree
- PCIe packet switches provide extension of the interface with intelligence
- Analog and Discrete solution provide power management and protection in both power and data lines

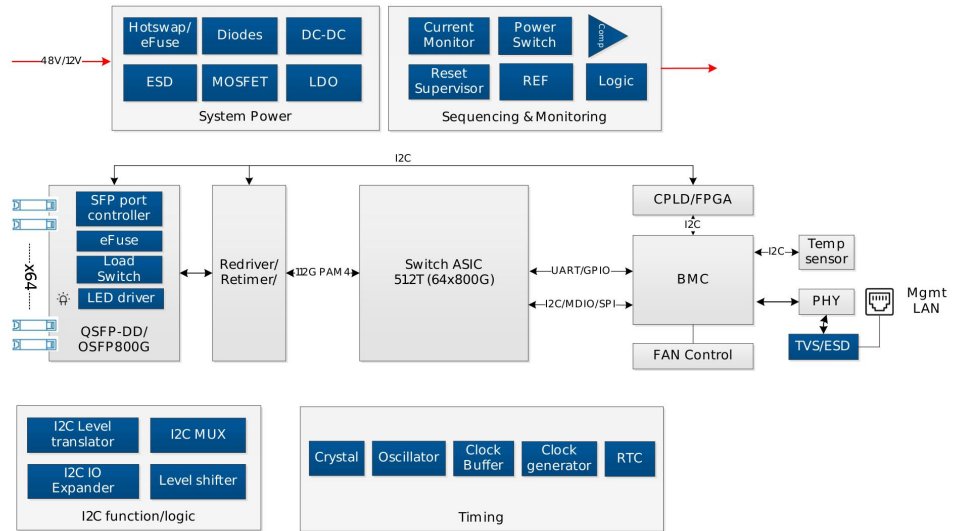

Diodes' Key Products	\$ / Box
Analog and Power Management	\$17.00
Discrete	\$5.00
Timing and Connectivity	\$50.00
Total	\$72.00

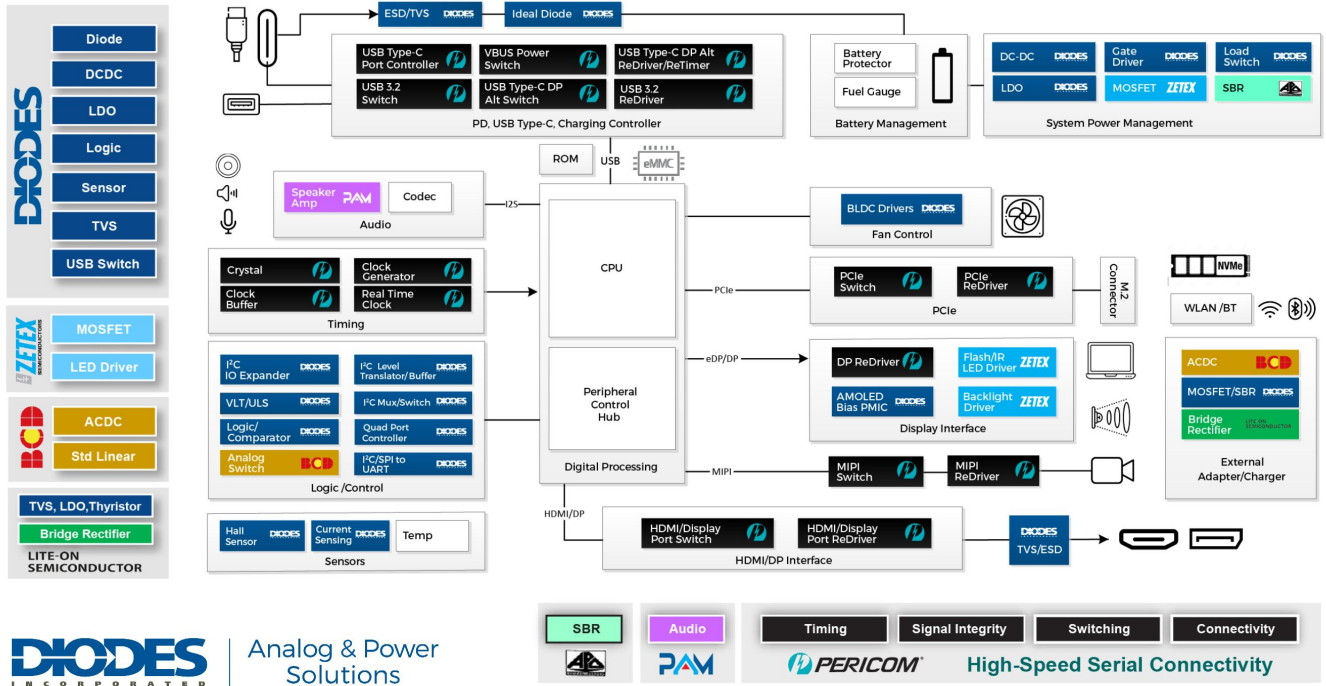

DIODES | Analog & Power Solutions



SBR
Audio
Timing
Signal Integrity
Switching
Connectivity

High-Speed Serial Connectivity

Products



- Packet Switches in AI server I/O port expansion
- eUSB/USB repeaters and Ultra-Low Cj TVS for signal integrity
- High performance MUX and Switch for high bandwidth/capacity storage
- High-voltage 60-100V LDOs, and DCDC for 48V rails
- USB-C / Power Delivery Solutions
- Isolation: Digital isolators and Gate Drivers
- Low-jitter timing solutions and high-speed PCIe packet switches for AI and cloud servers
- Ultra-low power and low-noise LDOs for IoT
- Lowest RDS(ON) LDMOS for battery efficiency
- IntellifET: self-protected power switches
- Advanced protection: IO and power lines
- 8V to 800V MOSFETs
- SiC Schottky Diodes and SiC MOSFETs for industrial and automotive applications

Wafer Fab

- High-performance 8" MOSFET trench technology
- Advanced Epi bipolar transistor processes
- Proprietary rectifier technology
- Rugged automotive-grade NMOS and PMOS
- Low-power, low-noise SiGe BiCMOS process
- High-voltage, high-power BCD process

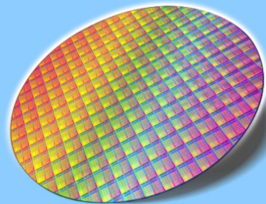

Assembly/Test

- Cu Pillar with flip chip on lead frame
- High pin-count BGA, LGA and AQFN packages
- Chip scale packaging with highest current density
- Compact QFN and DFN
- Power density PowerDI
- Small outline packages: down to 400 x 200µm

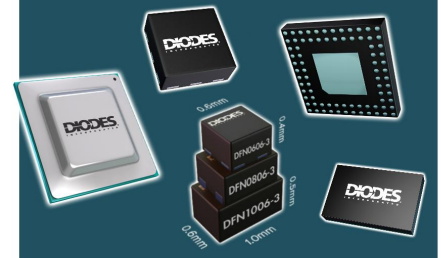

Analog & Power Solutions

Wafer Fabs

- US: South Portland, Maine
- China: Shanghai and Wuxi
- Taiwan: Hsinchu
- UK: Greenock and Oldham
- Bipolar, BiCMOS, CMOS, and BCD process
- Global footprint with strong engineering capabilities



Assembly and Test

- China: Shanghai, Chengdu, and Wuxi
- Taiwan: Chongli
- Germany: Neuhaus



Analog & Power
Solutions

By Channel

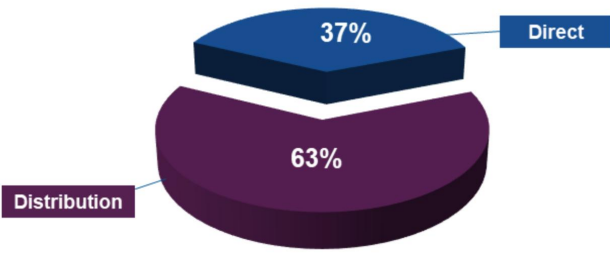

By Region

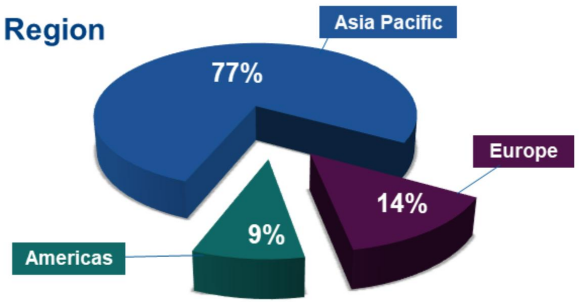

By End Market

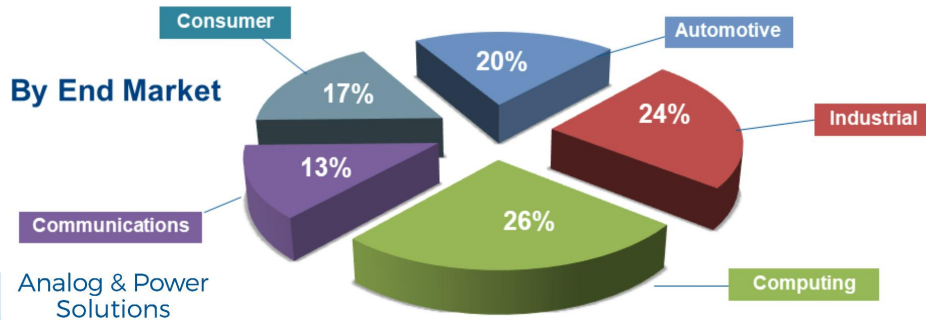

Analog & Power Solutions

(\$ in millions, except EPS)	1Q25	4Q25	1Q26
Net sales	332.1	391.6	405.5
Gross profit (GAAP)	104.7	121.9	128.8
Gross profit margin % (GAAP)	31.5%	31.1%	31.8%
Net income (GAAP)	(4.4)	10.2	15.0
Net income (non-GAAP)	8.8	15.4	19.8
Diluted EPS (non-GAAP)	0.19	0.34	0.43
Cash flow from operations	56.7	38.1	64.3
EBITDA (non-GAAP)	26.2	41.9	49.4



Analog & Power
Solutions

(\$ in millions)	Dec 31, 2024	Dec 31, 2025	Mar 31, 2026
Cash*	322	382	409
Inventory	475	472	493
Current assets	1,224	1,257	1,303
Total assets	2,386	2,448	2,498
Total debt	52	56	55
Total liabilities	517	510	547
Total equity	1,869	1,938	1,951

*Cash and cash equivalents, restricted cash, and short-term investments

- Revenue to be ~\$435 million, +/- 3.0%
representing 18.8% growth over the prior year period and a 7.3% increase sequentially at the mid-point, which is significantly better than typical seasonality
- GAAP gross margin of 32.8%, +/- 1%
- Non-GAAP adjusted EPS is expected to be \$0.60, plus or minus \$0.10



Analog & Power
Solutions

**Guidance as provided on May 7, 2026*

Vision:

- Inspire future technology through leading semiconductor solutions.

Mission:

- Deliver profitability growth through advanced analog and power solutions that enable innovation and efficiency across high-growth markets.

3-year Target : \$2B revenue and \$4+ non-GAAP EPS**Strategic Priorities:**

- Drive growth through a total system solutions sales approach and expanded solution-oriented content
- Deepen focus on key accounts to increase share of wallet
- Prioritize high-margin markets, including automotive, industrial, data center through analog & power solutions
- Invest in technology leadership across target products, fab processes, and advanced packaging
- Accelerate fab process and product qualifications



Analog & Power
Solutions

THANK YOU

diodes.com

*Inspiring future technology through
leading semiconductor solutions*